

## ASSEMBLY INSTRUCTION

### BS EN747-1:2012+A1:2015 SAFETY WARNING AND GENERAL NOTES: IMPORTANT – READ CAREFULLY – RETAIN FOR FUTURE REFERENCE

PLEASE READ this sheet prior to assembly to familiarise yourself with the various stages of construction. Carefully open the pack supplied and check the contents against the parts and fitting check list. Do not destroy any of the packing until you are certain that you have all the necessary parts for assembly.

**CAUTION :** There are small components used in the construction of this unit. These loose items should be kept away from young children whilst assembling your unit to avoid the danger of choking hazards.

### **WARNING :**







- Due to the size of this product we recommend that it is assembled in the room intended for use.
- This product should only be used on firm, level ground.
- **DO NOT** use power tools to construct this product.
- **DO NOT** over tighten the screw or bolts.
- **DO NOT** tighten screws until the product is fully assembled.
- **DO NOT** use solvent based cleaners or detergents as this can bleach and caused damages.
- Never use scourer, abrasives or chemical cleaners, only clean with sponge wipe and warm soapy water.
- High beds and the upper bed of the bunk beds are not suitable for children under six years due to the risk of injury from falls;
- Bunk beds and high beds can be present a serious risk of injury from strangulation if not used correctly. Never attach or hang items to any part of the bunk bed that are not designed to be used with the bed, for example, but not limited to ropes, strings, cords, hooks, belts and bags;
- Children can be trapped between the bed and wall, a roof pitch, the ceiling, adjoining pieces of furniture (e.g. cupboards) and the like. To avoid risk of serious injury the distance between the top safety barrier and the adjoining structure shall not exceed 75mm or shall be more than 230mm;
- Do not use the bunk bed/high bed if any structural part are missing, damaged or worn;
- Always follow the manufacturer's instruction
- Ensure thickness of mattress below the mark that had been made at the entrance of the upper bunk.
- Ensure the ventilation of the room is necessary in order to keep the humidity low and to prevent, mould in and around the bed.
- Ensure the support legs remain in contact with the ground at all times, and always use the ladder for entering and leaving the high bed and upper bunk.
- Ensure all screws or bolts are tightened and inspect regularly.
- Recommended size of top mattress 190(L) X 90(W) cm.

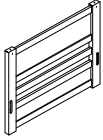
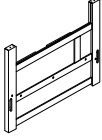
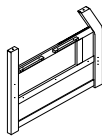
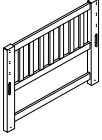
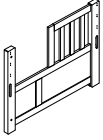
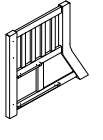
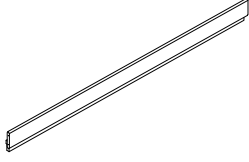
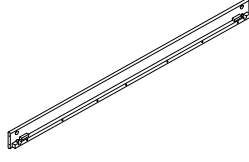
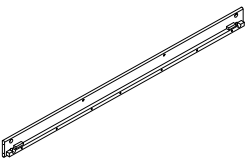
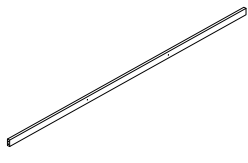
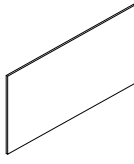
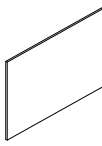

# PARTS LIST

Carton 1 of 4			Carton 2 of 4		
No.	Part Name	Pcs	No.	Part Name	Pcs
A	Lower Bunk Head Board Left	1	G	LOWER BUNK SIDERAIL (OUTTER)	1
B	Lower Bunk Head Board Middle	1	H	LOWER BUNK SIDERAIL (INNER)	1
C	Lower Bunk Head Board Right	1	I	UPPER BUNK SIDERAIL	2
D	Upper Bunk Head Board Left	1	J	UPPER BUNK BARRIER	6
E	Upper Bunk Head Board Middle	1	W	DRAWER LARGE DRAWER TOP	2
F	Upper Bunk Head Board Right	1	X	DRAWER LARGE BLACK SIDE	2
Z	Drawer Large Bottom Board	1	Y	DRAWER SIDE BOARD	4
<b>FITTING LIST</b>			E1	UPPER BUNK BARRIER SUPPORT	4
Carton 3 of 4			Carton 4 of 4		
K	Headboard Panel	1	D1	SLATS ROLL	2
L	Headboard Panel	1			
M	HEAD BOARD BAR LEFT	1			
N	HEAD BOARD RIGHT	1			
O	HEADBOARD PANEL RIGHT	1			
P	BLOCK DRAWER BAR	1			
Q	LADDER PANEL	1			
R	LADDER PANEL 1	1			
S	LADDER PANEL 2	1			
T	LADDER PANEL 3	1			
U	LADDER PANEL 4	4			
V	BACK PANEL	1			
Y	DRAWER SIDE BOARD	2			
A1	DRAWER SMALL DRAWER TOP	1			
B1	DRAWER SMALL BLACK SIDE	1			
C1	DRAWER SMALL BOTTOM BOARD	1			

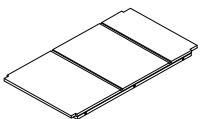
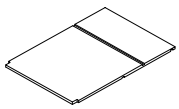
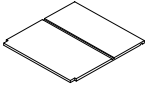
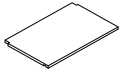
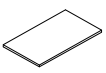
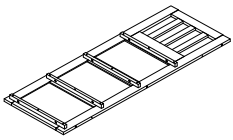
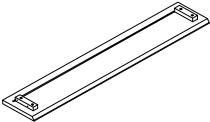
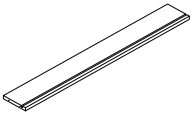
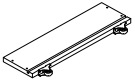
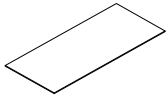
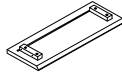
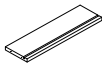
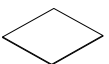
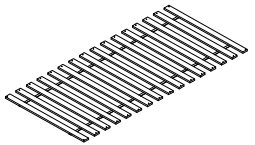
VIUSUAL IDENTIFICATION

<u>Item Description</u>	<u>Qty</u>	<u>Item Description</u>	<u>Qty</u>	<u>Item Description</u>	<u>Qty</u>	<u>Item Description</u>	<u>Qty</u>
							
Lower Bunk A Head Board Left	1pc	Lower Bunk B Head Board Middle	1pc	Lower Bunk C Head Board Right	1pc	Upper Bunk D Head Board Left	1pc
							
Upper Bunk E Head Board Middle	1pc	Upper Bunk F Head Board Right	1pc	Lower Bunk G Siderail (Outer)	1pc	Lower Bunk H Siderail (Inner)	1pc
							
Upper Bunk I Siderail	2pcs	Upper Bunk J Barrier	6pcs	Head board K Panel	1pc	Head board L Panel	1pc
							
Headboard M Bar Left	1pc	Headboard N Bar Right	1pc	Headboard O Panel Right	1pc	P Block Drawer Bar	1pc
							
Q Ladder Panel	1pc	R Ladder Panel 1	1pc	S Ladder Panel 2	1pc	T Ladder Panel 3	1pc
							
U Panel	4pcs	V Back Panel	1pc	Drawer Large W Drawer Top	2pcs	Drawer Large X Back Side	2pcs
							
Drawer Y Side Board	6pcs	Drawer Large Z Bottom Board	2pcs	Drawer Small A1 Drawer Top	1pc	Drawer Small B1 Back Side	1pc
							
Drawer Small C1 Bottom Board	1pc	D1 Slats Roll	2set	Upper Bunk E1 Barrier Support	4pcs		

FITTINGS CHECKLISTS

Code Description Qty

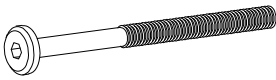

1 Bolt M6x80 16pcs

Code Description Qty



2 Half Moon Washer 16pcs

Code Description Qty

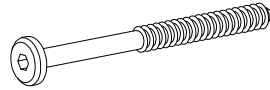

3 Bolt 7.0x80 12pcs

Code Description Qty



4 Bolt M6x50 8pcs

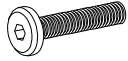

5 Bolt M6x28 22pcs

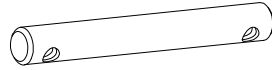

6 Nuts Ø10x80xM6 06pcs

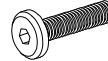

7 Bolt M6x25 36pcs

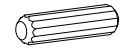

8 Wood Dowel Ø8x30 20pcs



9 Screw 4x30 88pcs



10 Allen key 1pc

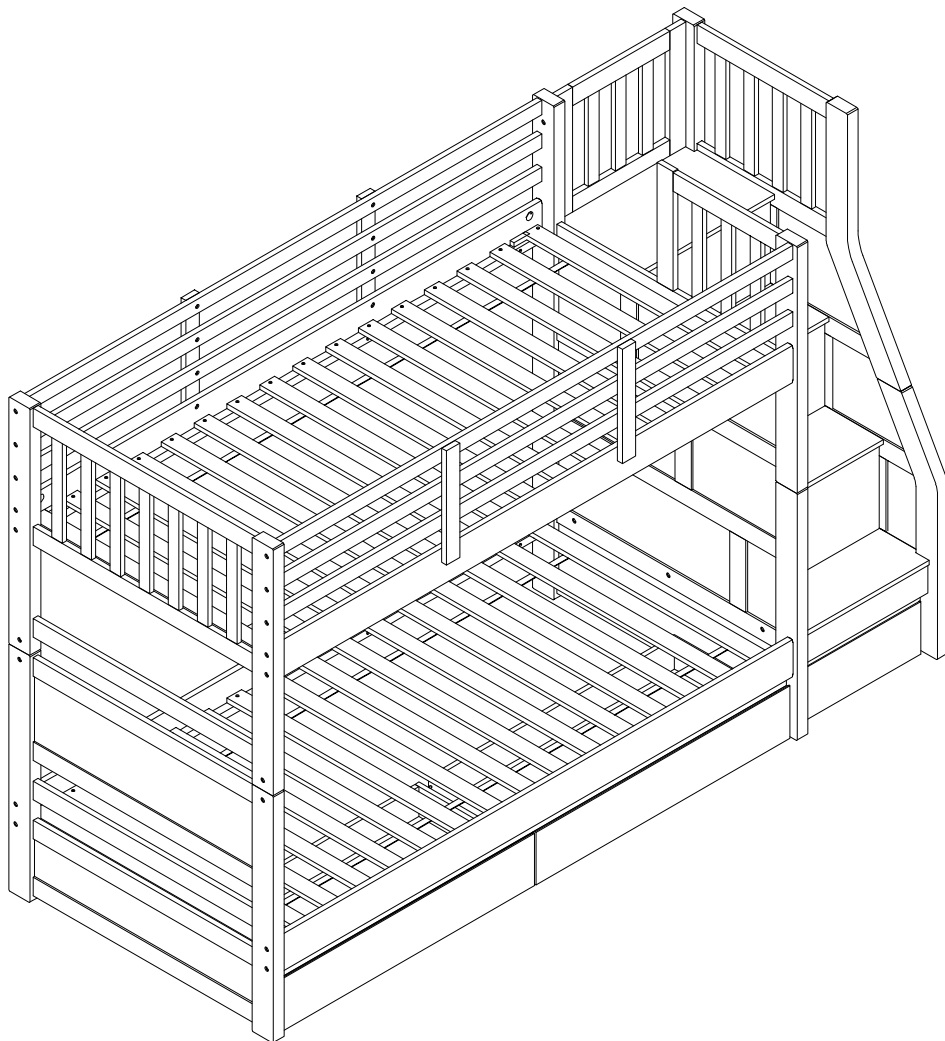

# Step 1.

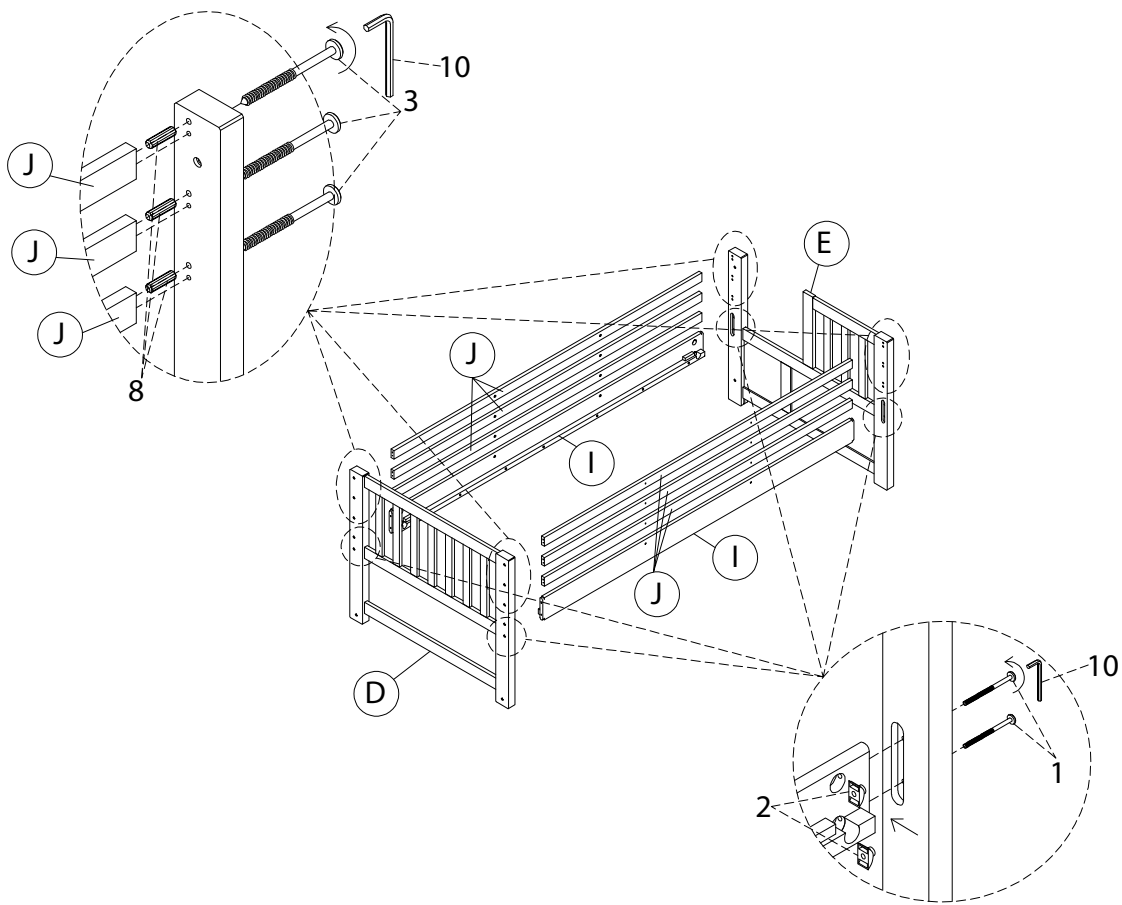

## Part

## Hardware

Item   Description   Qty

Item   Description   Qty

Code   Description   Qty

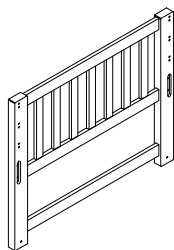

D   Upper Bunk Head Board Left   1pc

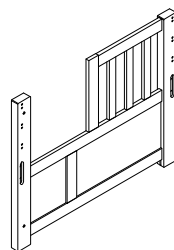

E   Upper Bunk Head Board Middle   1pc

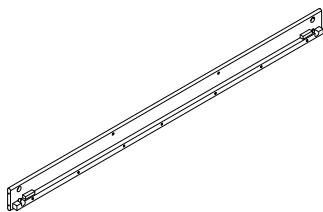

I   Upper Bunk Siderail   2pcs

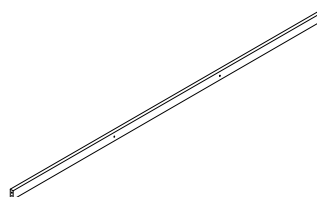

J   Upper Bunk Barrier   6pcs



1   Bolt M6x80   8pcs



2   Half Moon Washer   8pcs

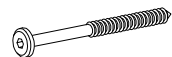

3   Bolt 7.0x80   12pcs



8   Wood Dowel Ø8x30   12pcs



10   Allen key   1pc

## Step 2.

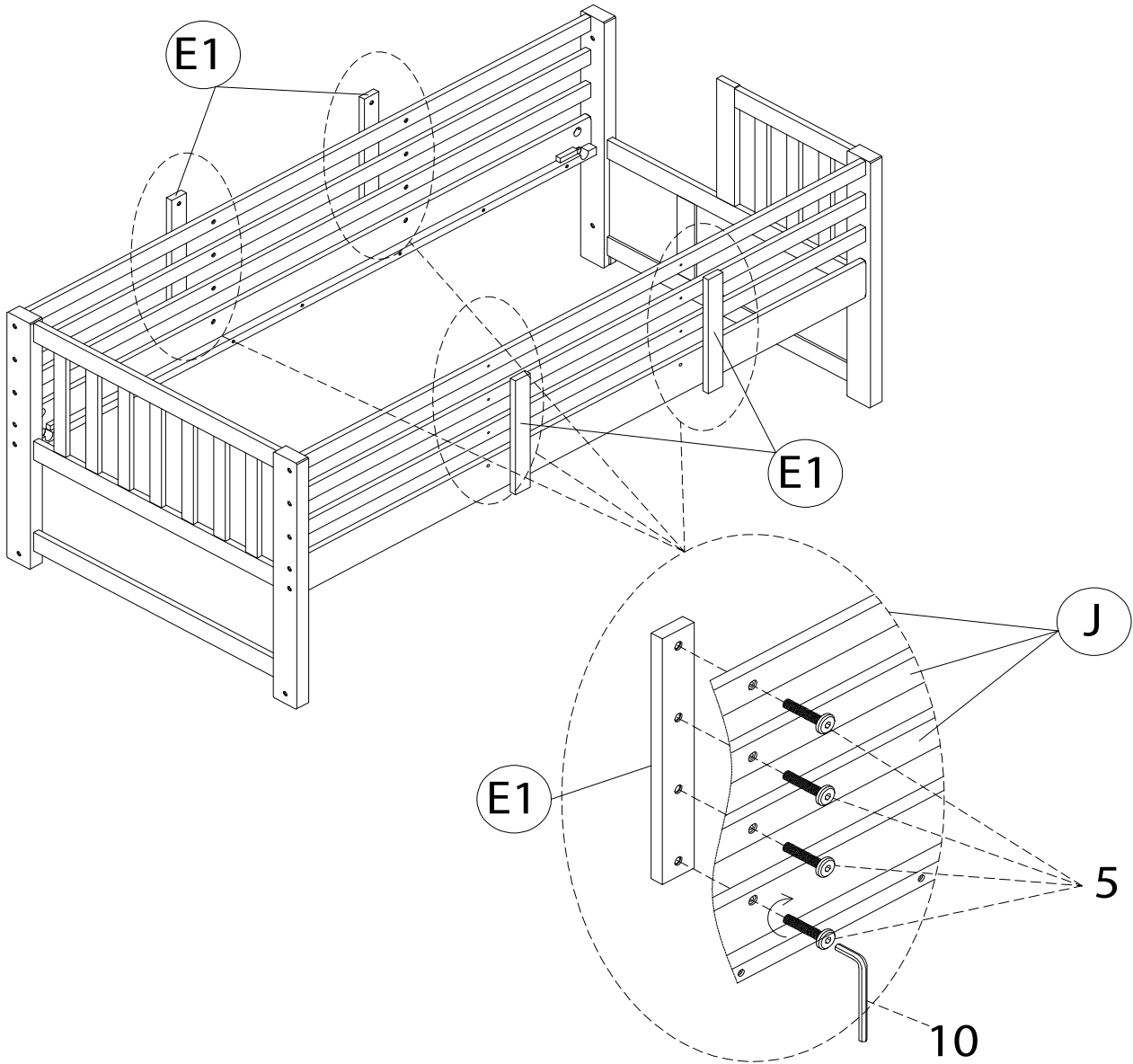

### Part

Item	Description	Qty
E1	Upper Bunk Barrier Support	4pcs



E1 Upper Bunk Barrier Support 4pcs

### Hardware

Code	Description	Qty
5	Bolt M6x28	16pcs
10	Allen key	1pc

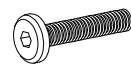

5 Bolt M6x28 16pcs



10 Allen key 1pc

### Step 3.

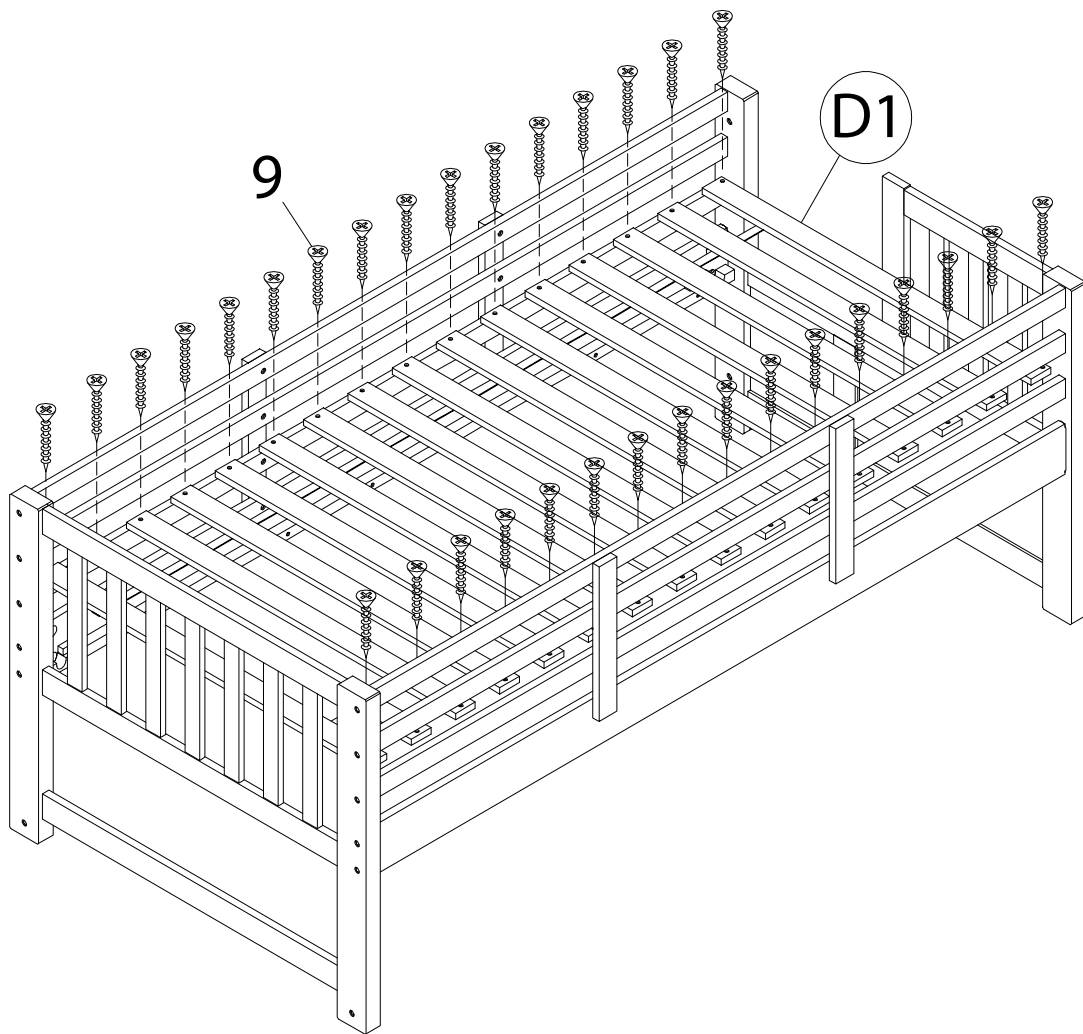

### Part

### Hardware

Item Description Qty

Code Description Qty

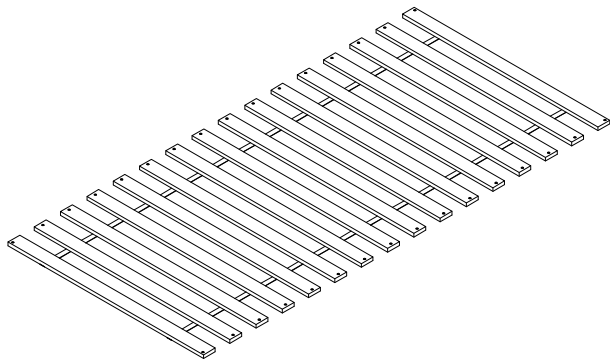

9 Screw 4x30 32pcs

D1 Slats Roll 1set

# Step 4.

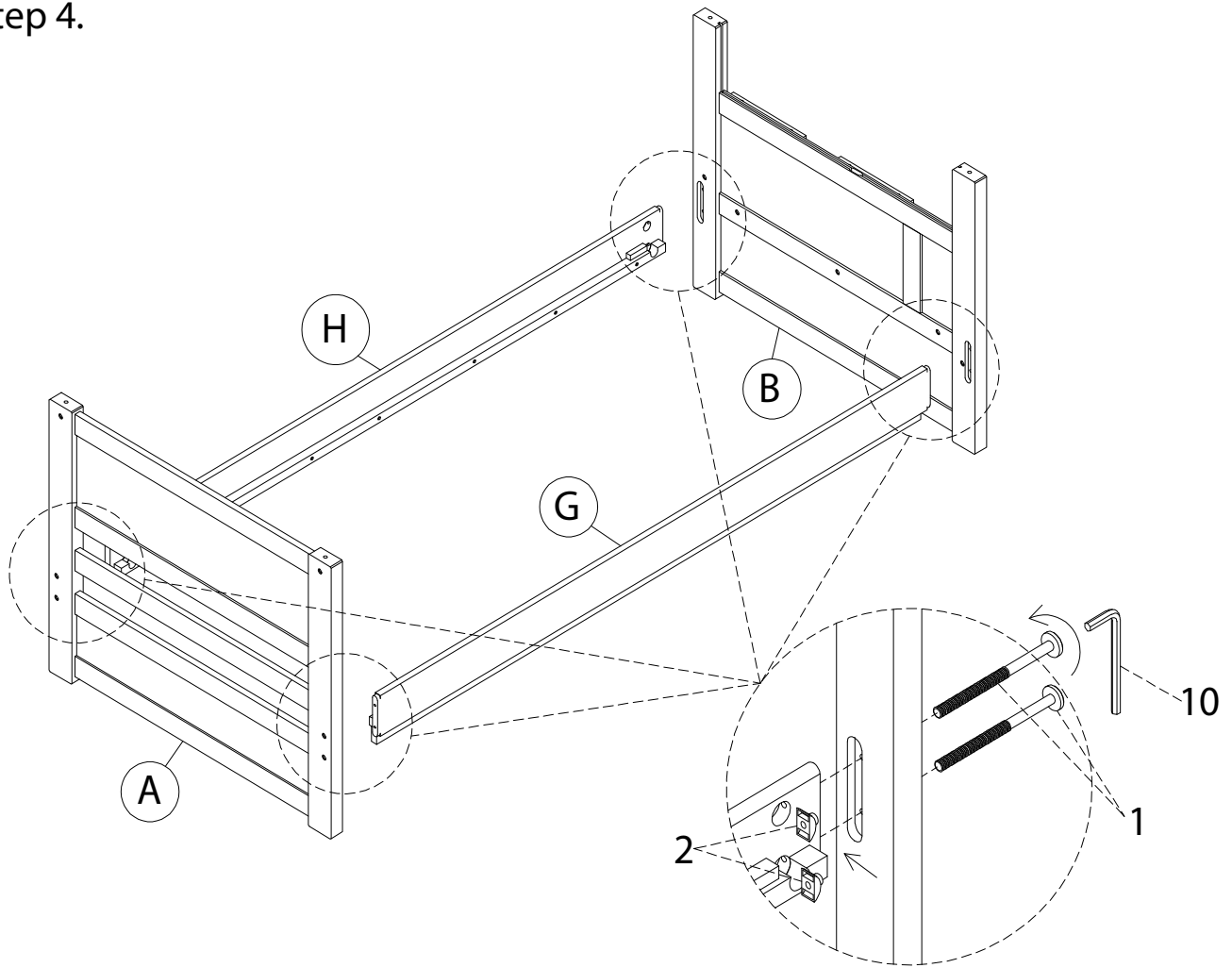

## Part

## Hardware

Item Description Qty

Item Description Qty

Code Description Qty

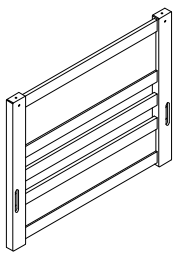

Lower Bunk  
A Head Board Left 1pc

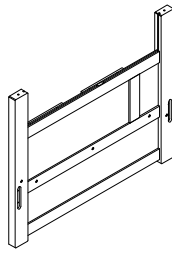

Lower Bunk  
B Head Board Middle 1pc



1 Bolt M6x80 8pcs



2 Half Moon Washer 8pcs

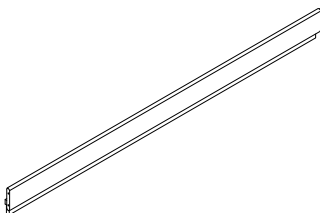

Lower Bunk  
G Siderail (Outer) 1pc

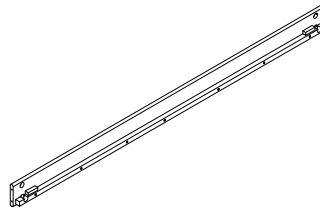

Lower Bunk  
H Siderail (Inner) 1pc







10 Allen key 1pc

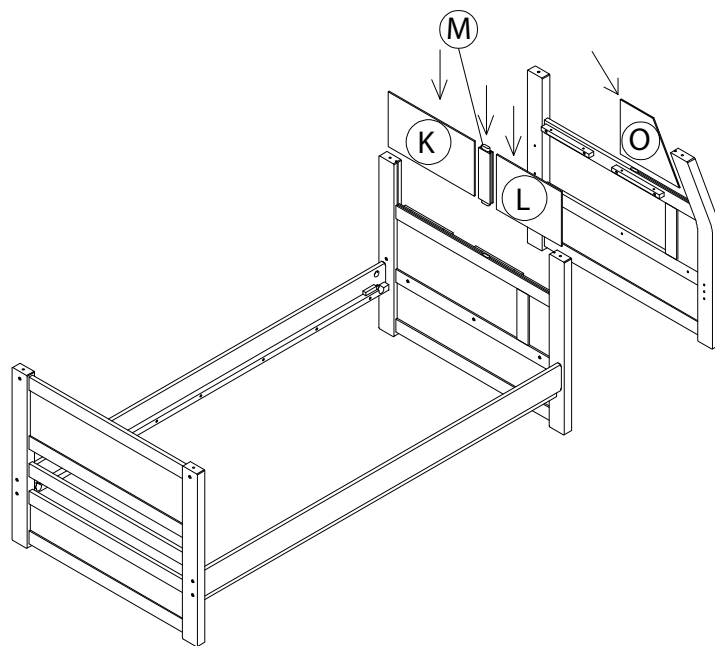

## Step 5.





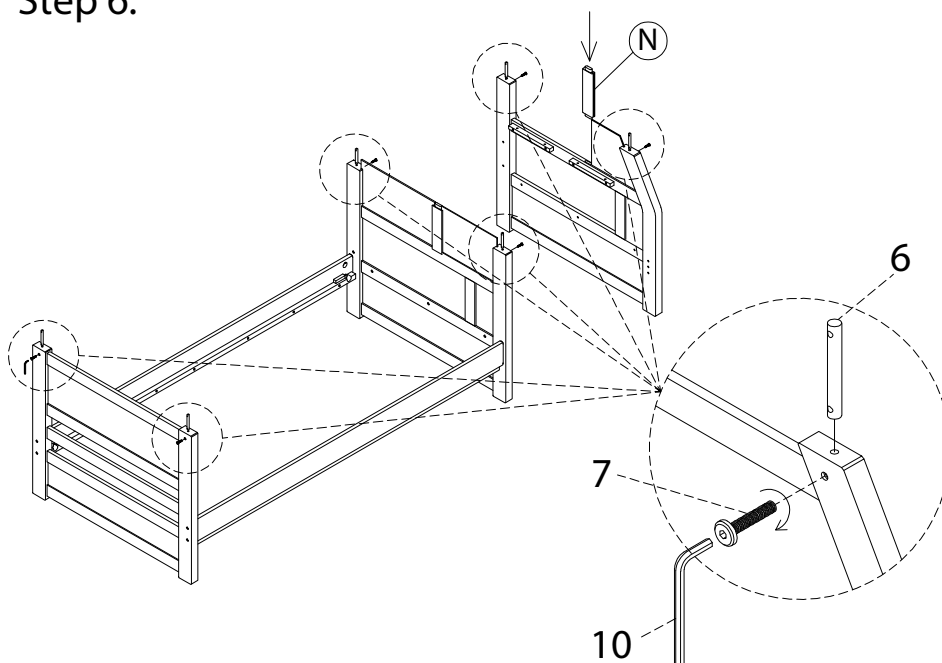

Item	Description	Qty	Item	Description	Qty	Item	Description	Qty	Item	Description	Qty
	Headboard Panel K	1pc		Headboard Panel L	1pc		Headboard Bar M	1pc		Headboard Panel O	1pc

## Step 6.



### Hardware

Code	Description	Qty
	Nuts Ø10x80xM6	06pcs
	Bolt M6x25	6pcs
	Allen key	1pc

Item	Description	Qty
	Headboard Bar N	1pc

# Step 8.

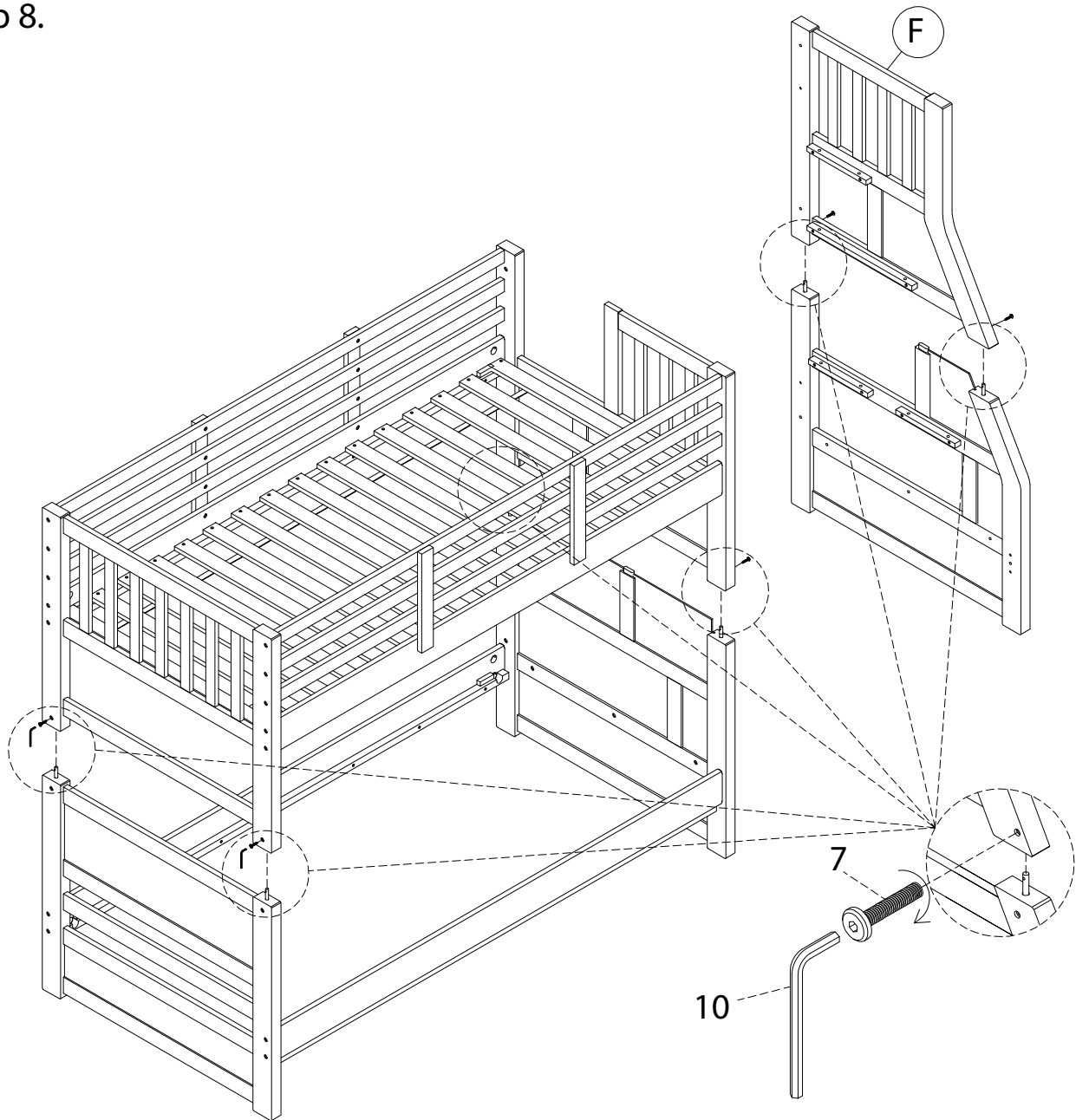

Part

Hardware

Item Description Qty

Code Description Qty

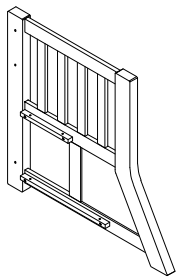

Upper Bunk  
F Head Board Right 1pc

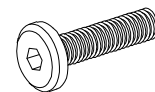

7 M6x25 6pcs



10 Allen key 1pc

# Step 9.

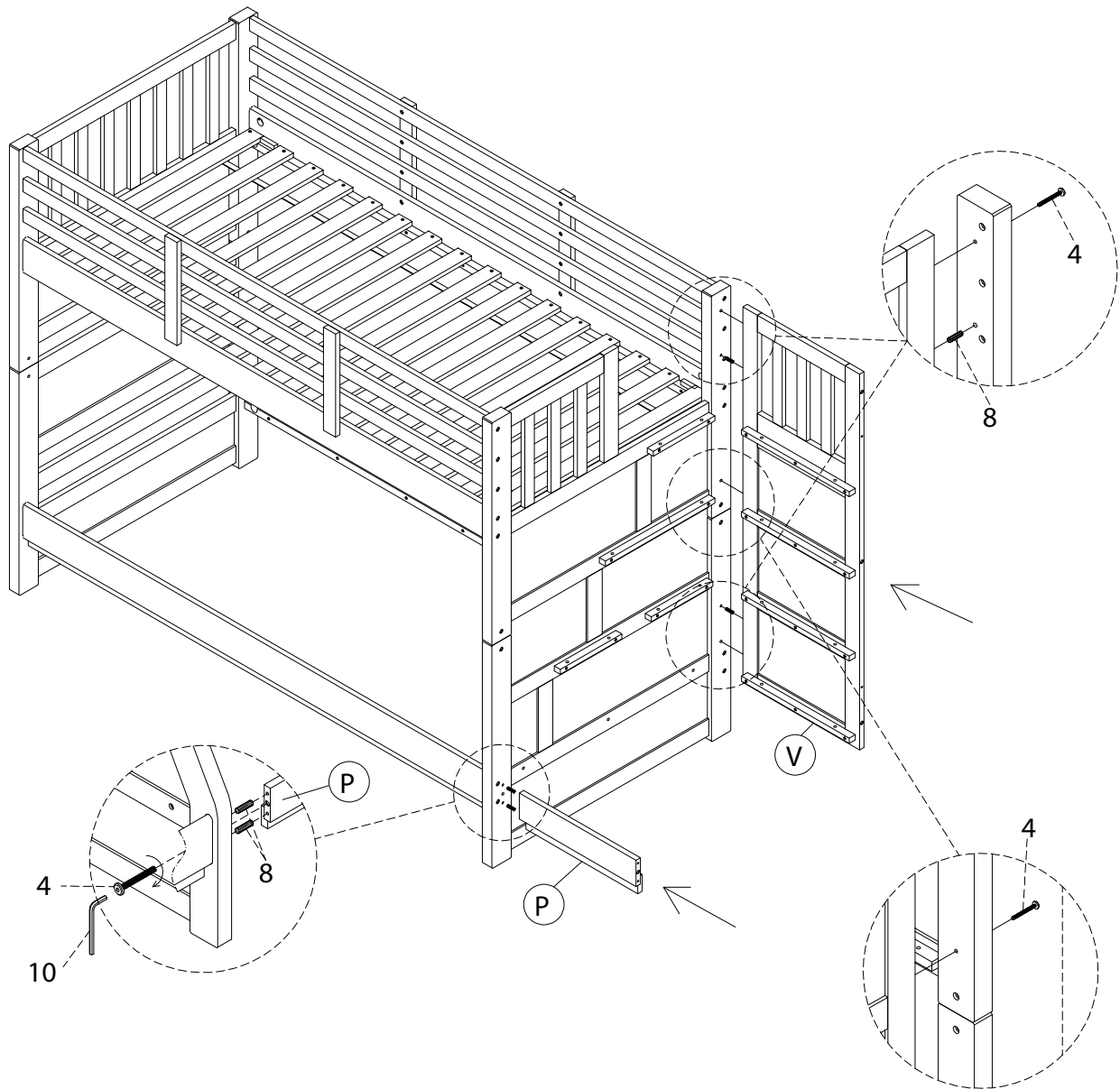

## Part

Item   Description   Qty

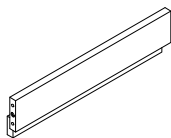

P Block Drawer Bar 1pc

Item   Description   Qty

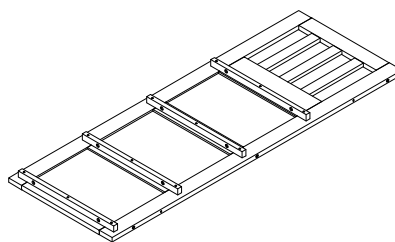

V Back Panel 1pc

## Hardware

Code   Description   Qty



4 Bolt M6x50 4pcs



8 Wood Dowel Ø8x30 4pcs



10 Allen key 1pc

# Step 10.

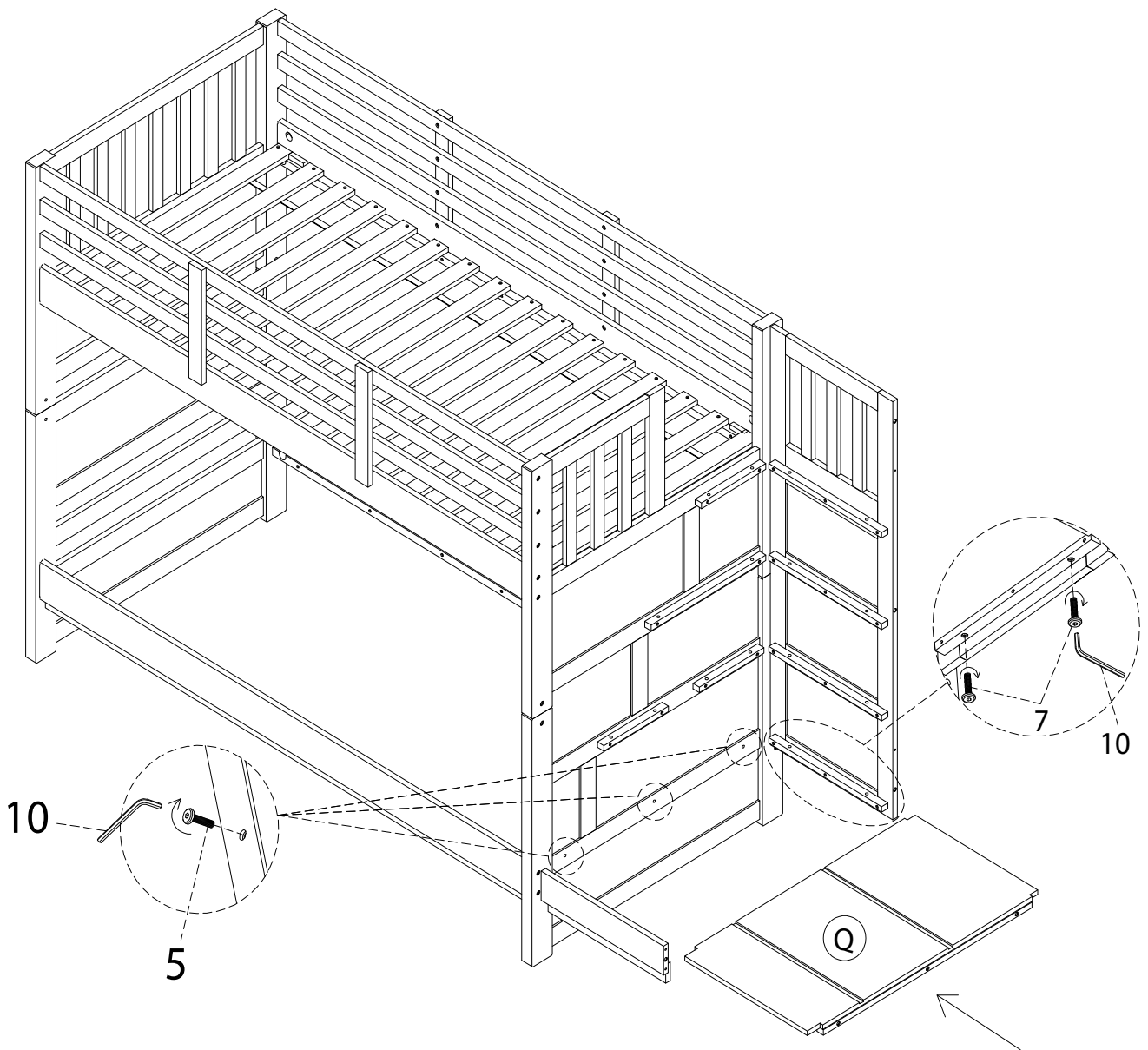

## Part

Item Description Qty

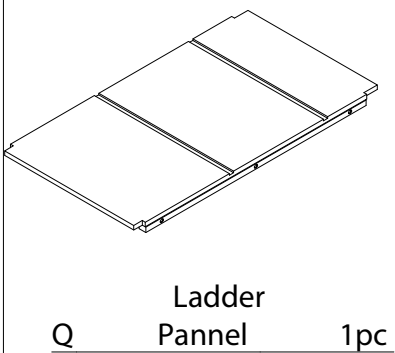

## Hardware

Code Description Qty

5 Bolt M6x28 3pcs

7 Bolt M6x25 2pcs

10 Allen key 1pc

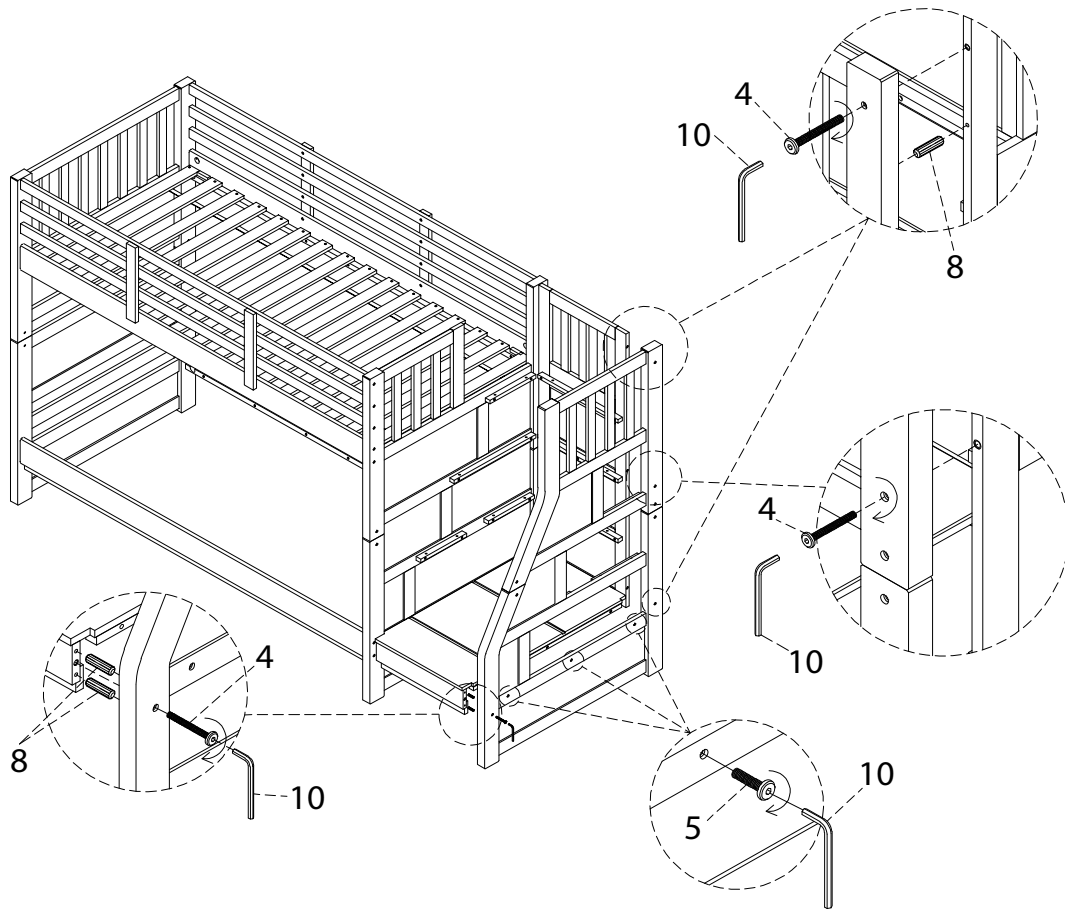

## Step 11.

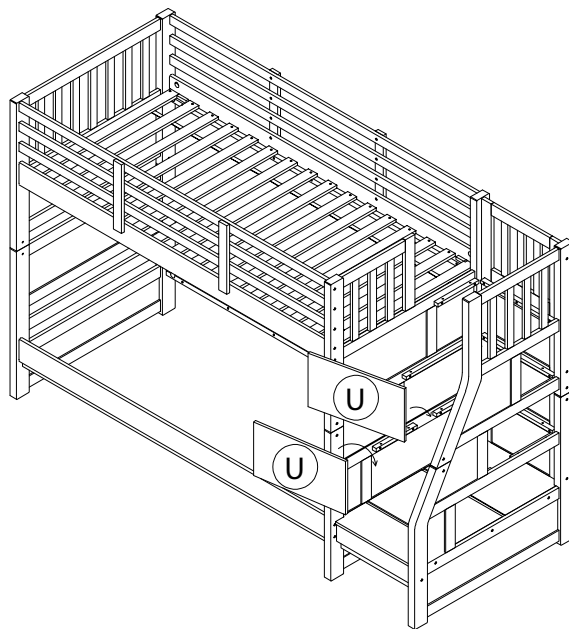

## Step 12.

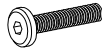

### Hardware

Code	Description	Qty
4	 Bolt M6x50	4pcs
5	 Bolt M6x28	3pcs
8	 Wood Dowel Ø8x30	4pcs
10	 Allen key	1pc

### Part

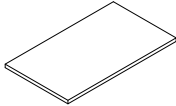
Item Description	Qty
	
<b>U</b> Panel	2pcs

### Step 13.

### Hardware

Code	Description	Qty
7	Bolt M6x25	10pcs
10	Allen key	1pc

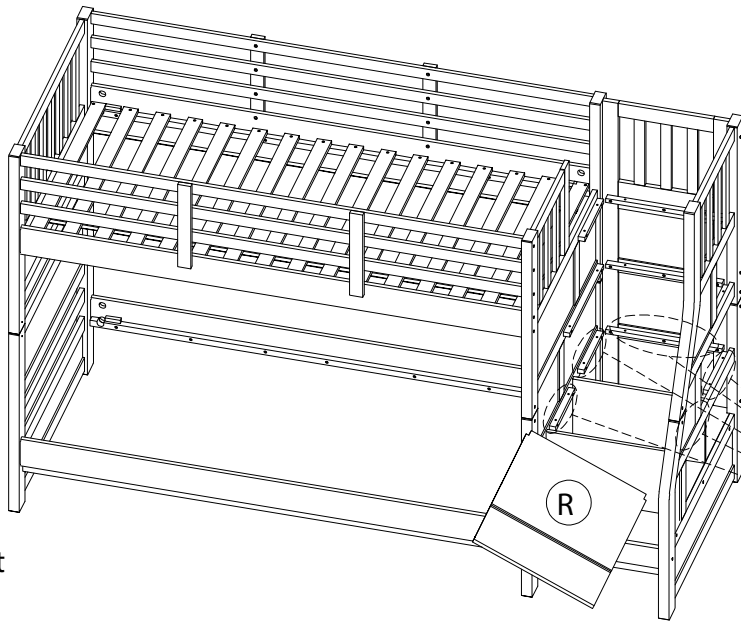

Part

Item Description Qty

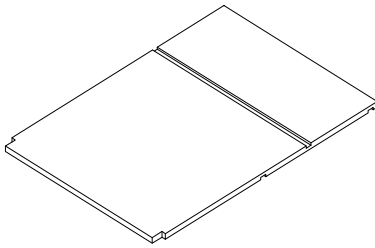

R Ladder Panel 1 1pc

### Step 14.

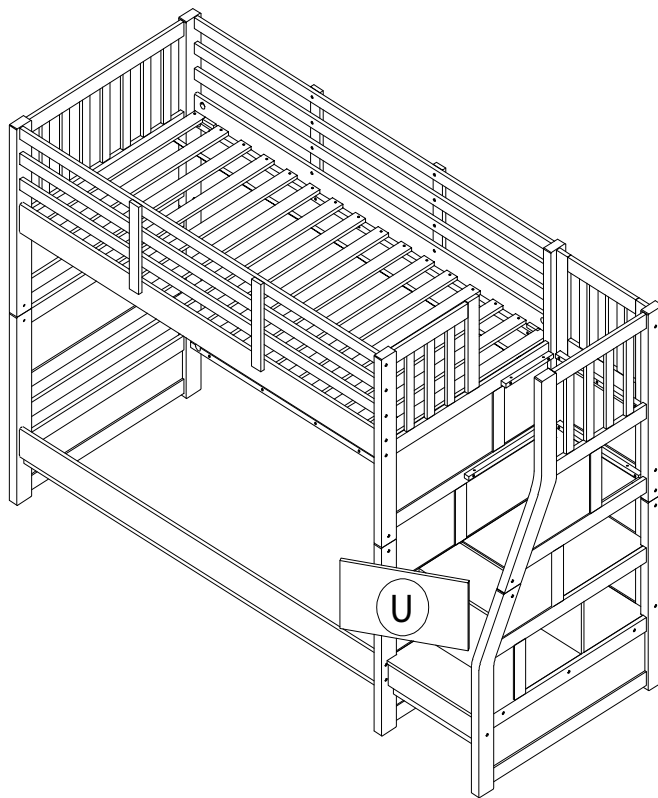

Part

Item Description Qty

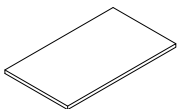

U Panel 1 1pc

## Step 15.

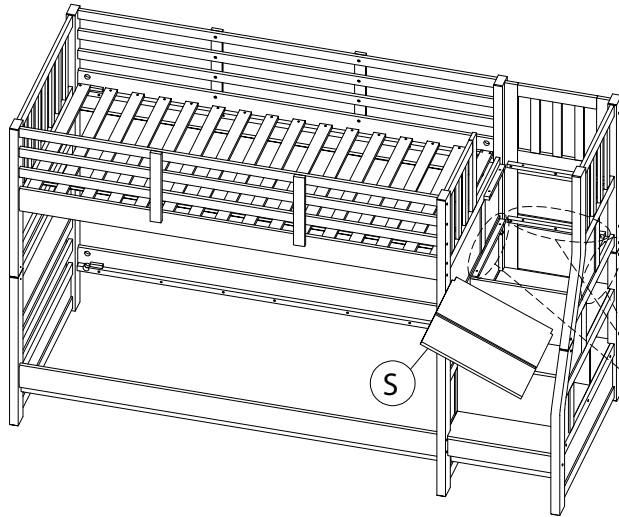

### Hardware

Code	Description	Qty
7	Bolt M6x25	6pcs
10	Allen key	1pc

### Part

Item Description Qty

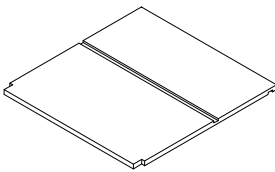

S Ladder Panel 2 1pc

## Step 16.

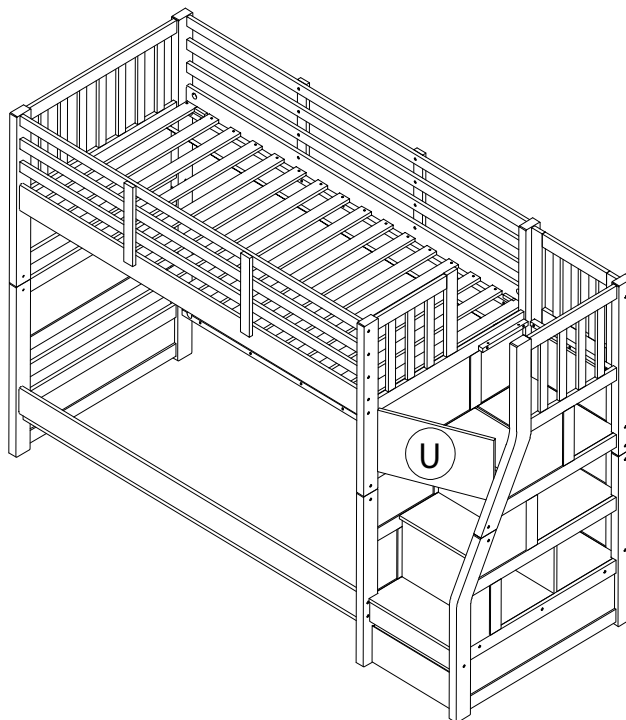

### Part

Item Description Qty

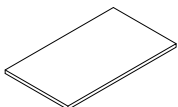

U Panel 1pc

## Step 17.

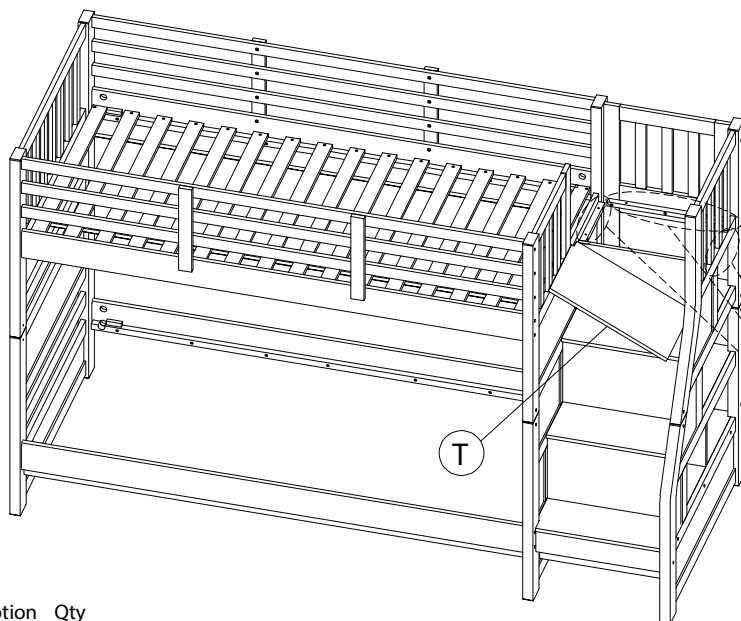

Hardware		
Code	Description	Qty
7	Bolt M6x25	6pcs
10	Allen key	1pc

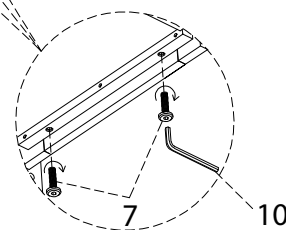

### Part

Item Description Qty

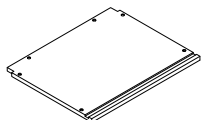

T Ladder  
Pannel 3 1pc

## Step 18.

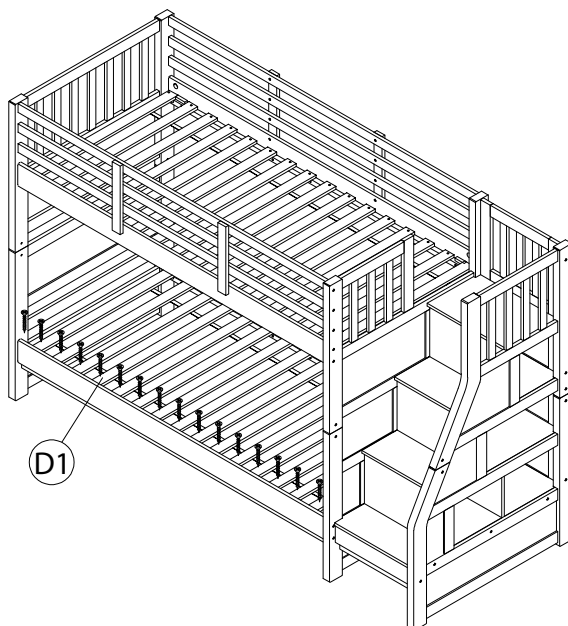

### Part

Item Description Qty

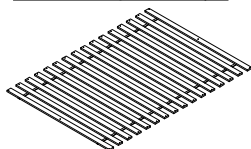

D1 Slats Roll 1set

### Hardware

Code	Description	Qty
9	Screw 4x30	32pcs





## Step 19.

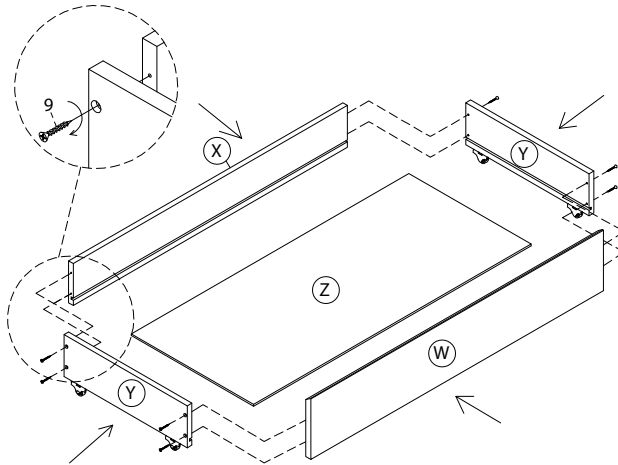

Hardware  
Code Description Qty

9  Screw 4x30 16pcs

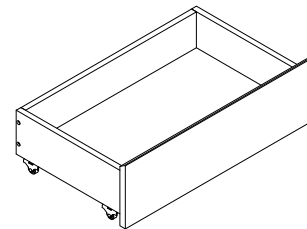

Large box: 2PCS

### Part

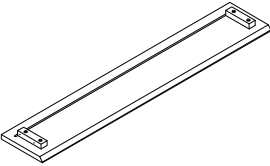
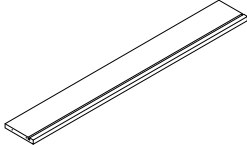
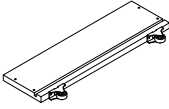
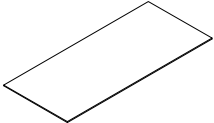
Item	Description	Qty	Item	Description	Qty	Item	Description	Qty	Item	Description	Qty
	Drawer Large W Drawer Top	2pcs		Drawer Large X Back Side	2pcs		Drawer Y Side Board	4pcs		Drawer Large Z Bottom Board	2pcs

## Step 20.

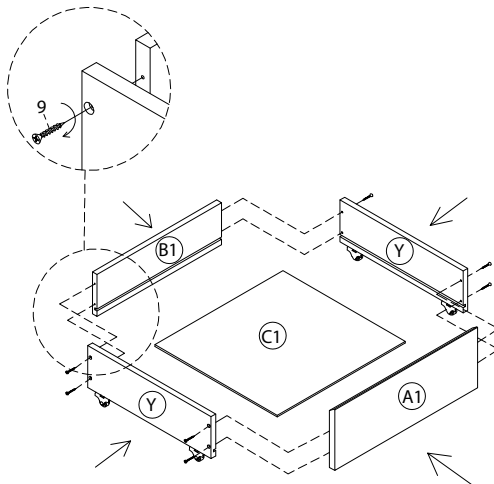

Hardware  
Code Description Qty

9  Screw 4x30 8pcs

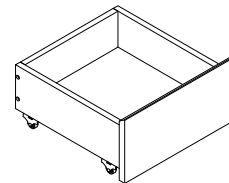

Small box: 1PC

### Part

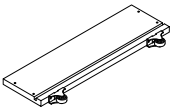
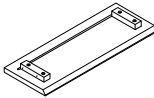
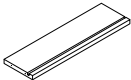
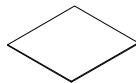
Item	Description	Qty	Item	Description	Qty	Item	Description	Qty	Item	Description	Qty
	Drawer Y Side Board	2pcs		Drawer Small A1 Drawer Top	1pc		Drawer Small B1 Back Side	1pc		Drawer Small C1 Bottom Board	1pc

FINISH

