

ASSEMBLY INSTRUCTIONS

1
6

MODEL : CK 6233

PRODUCT SIZE : 900mm(L) x 596mm(W) x 700mm(H)

Thank you for purchasing this product. Before starting assembly we suggest you spend a short time reading through this leaflet, then follow the simple step by step guide.
Two persons are needed to assemble this product.



* Approximately 1 Hours



* 2 People Required

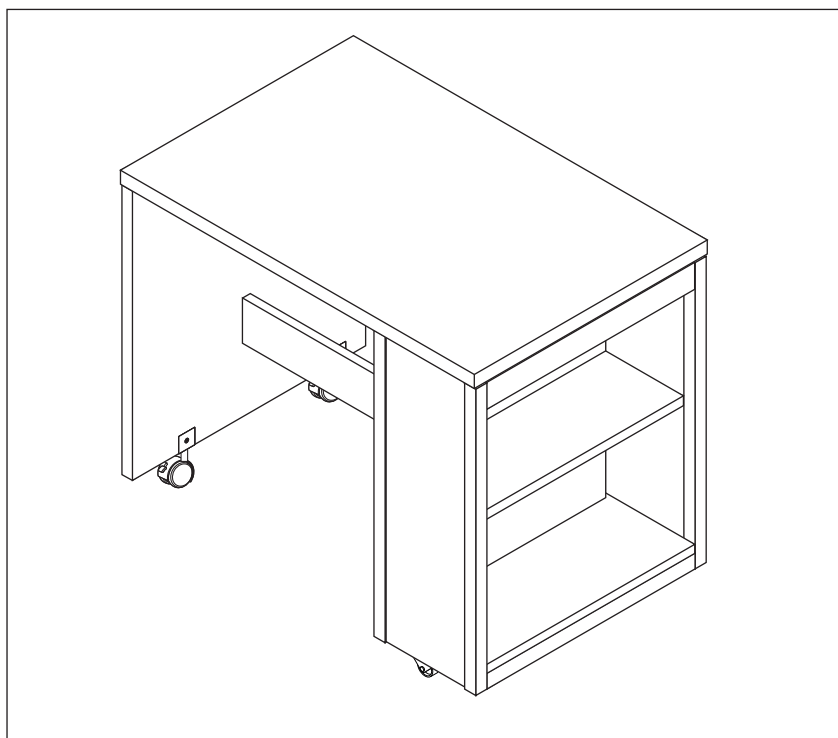

Ensure that you check regularly that all bolt are securely fastened and all components are in place.

If spare parts are required, contact your dealer.Do not use substitute part.

This instructions should be kept in a safe place for future reference.

Tools Required For Assembly



Tools Not Use

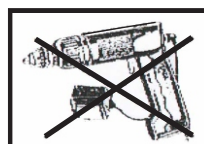

DO NOT USE POWER TOOLS TO ASSEMBLE THIS PRODUCT. USE OF POWER TOOLS WILL INVALIDATE ANY CLAIM AND MAY DAMAGE THIS PRODUCT MAKING IT UNSAFE.













DO NOT USE HAMMER

PARTS LIST

2 6

Model: CK 6233

Carton 1 of 1			Hardware		
No.	Part Name	Pcs	No.	Part Name	Pcs
⑳	PLINTH PANEL (DESK)	1	Ⓐ	Cam 	28
㉑	BOTTOM PANEL (DESK)	1	Ⓑ	Cam Stud (5137) 	28
㉒	CENTER PANEL (DESK)	1	Ⓒ	M8 x 25mm Wood Dowel 	48
㉓	RIGHT PANEL (DESK)	1	Ⓓ	15mm Chipboard Screw 	4
㉔	RIGHT POST BACK (DESK)	1	Ⓔ	M6 x 25mm Allen Bolt 	2
㉕	RIGHT POST FRONT (DESK)	1	Ⓕ	40mm Plate Nylon Caster 	2
㉖	BACK PANEL (DESK)	1	Ⓖ	16.5mm U Shape PP Caster 	2
㉗	FRONT PANEL (DESK)	1	Ⓗ	M6 Cap Nut 	2
㉘	LEFT PANEL (DESK)	1	Ⓙ	Spanar 	1
㉙	LEFT POST BACK (DESK)	1	Ⓚ	M6 Allen Wrench 	1
㉚	LEFT POST FRONT (DESK)	1			
㉛	CENTER SUPPORT PANEL (DESK)	1			
㉜	BACK PANEL (DESK)	1			
㉝	TOP PANEL (DESK)	1			
FITTING LIST					

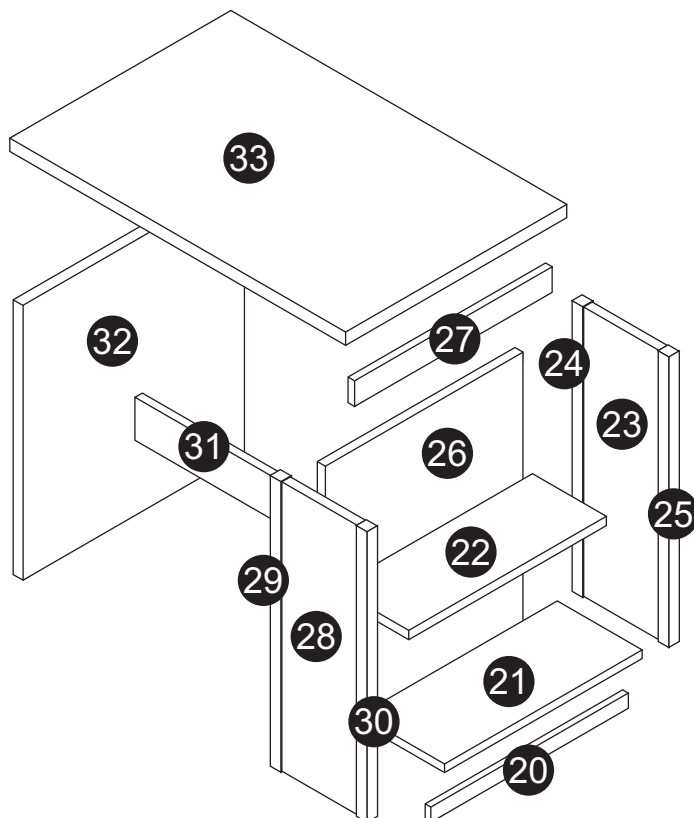

CAUTION
 There are many small components used in the construction of this unit. These loose items should be kept away from young children whilst assembling your unit. As an extra precaution, screw cover caps should be permanently fixed in position. (Where applicable)

USEFUL HINTS & TIPS
 Two people will be required to assemble this unit

Please keep this assembly instruction for future reference

GUIDE TO ASSEMBLY

3
6

Model: CK 6233

STEP 1

WHEN FITTING CAMS

ENSURE STARTING POSITION IS CORRECT
BEFORE YOU INSERT CONNECTING BOLT
TURN CLOCKWISE UNTIL SECURE

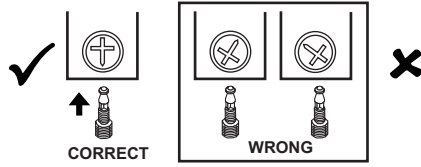

B x 5



A x 26



C x 45

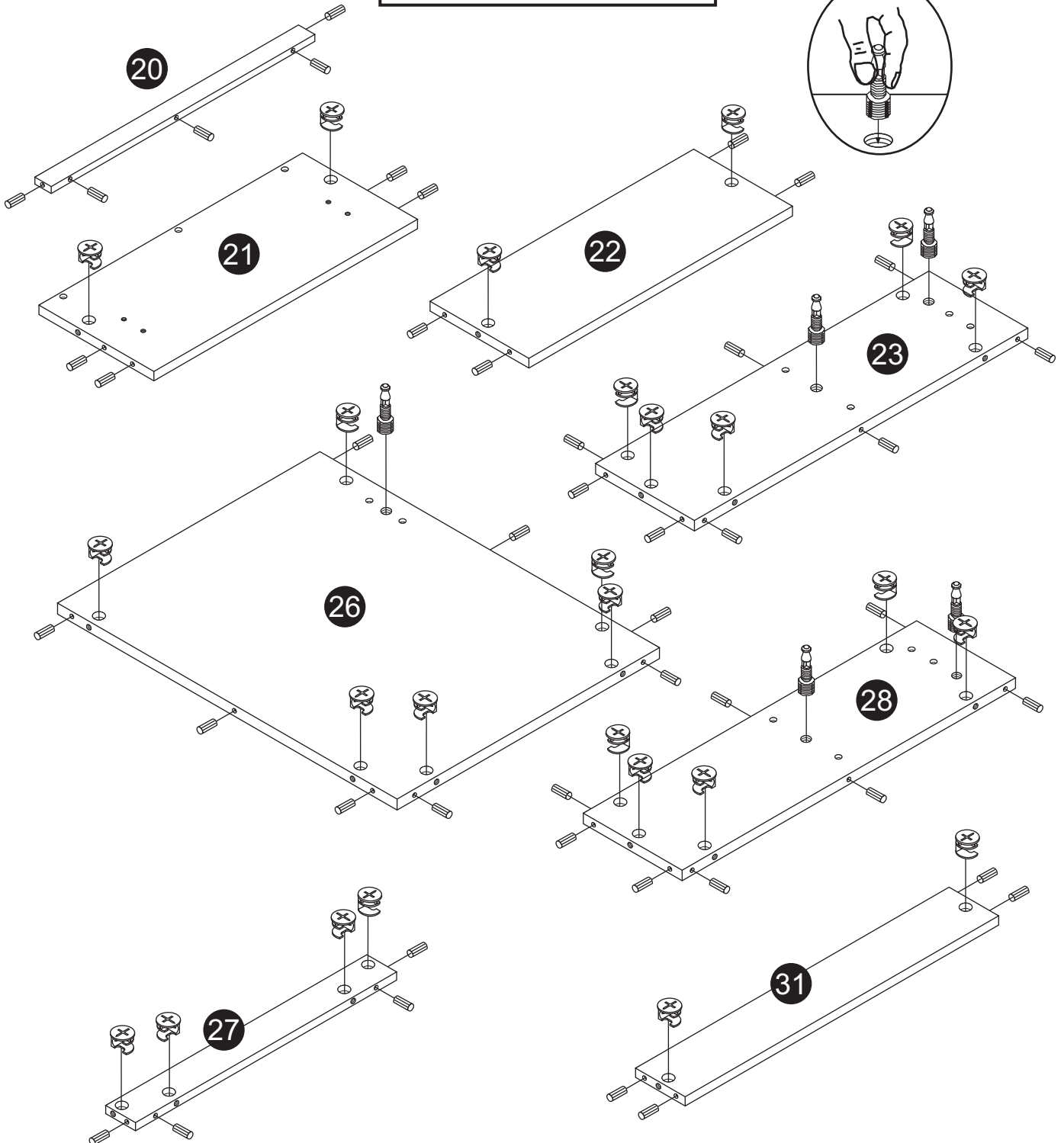
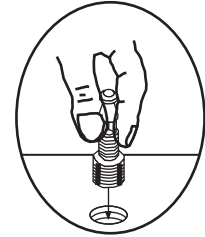

GUIDE TO ASSEMBLY

4
6

Model: CK 6233

STEP 2

WHEN FITTING CAMS

ENSURE STARTING POSITION IS CORRECT
BEFORE YOU INSERT CONNECTING BOLT
TURN CLOCKWISE UNTIL SECURE

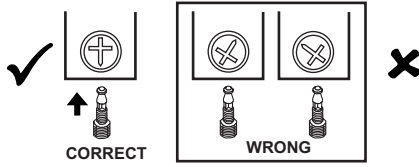

B x 23



A x 2



C x 3

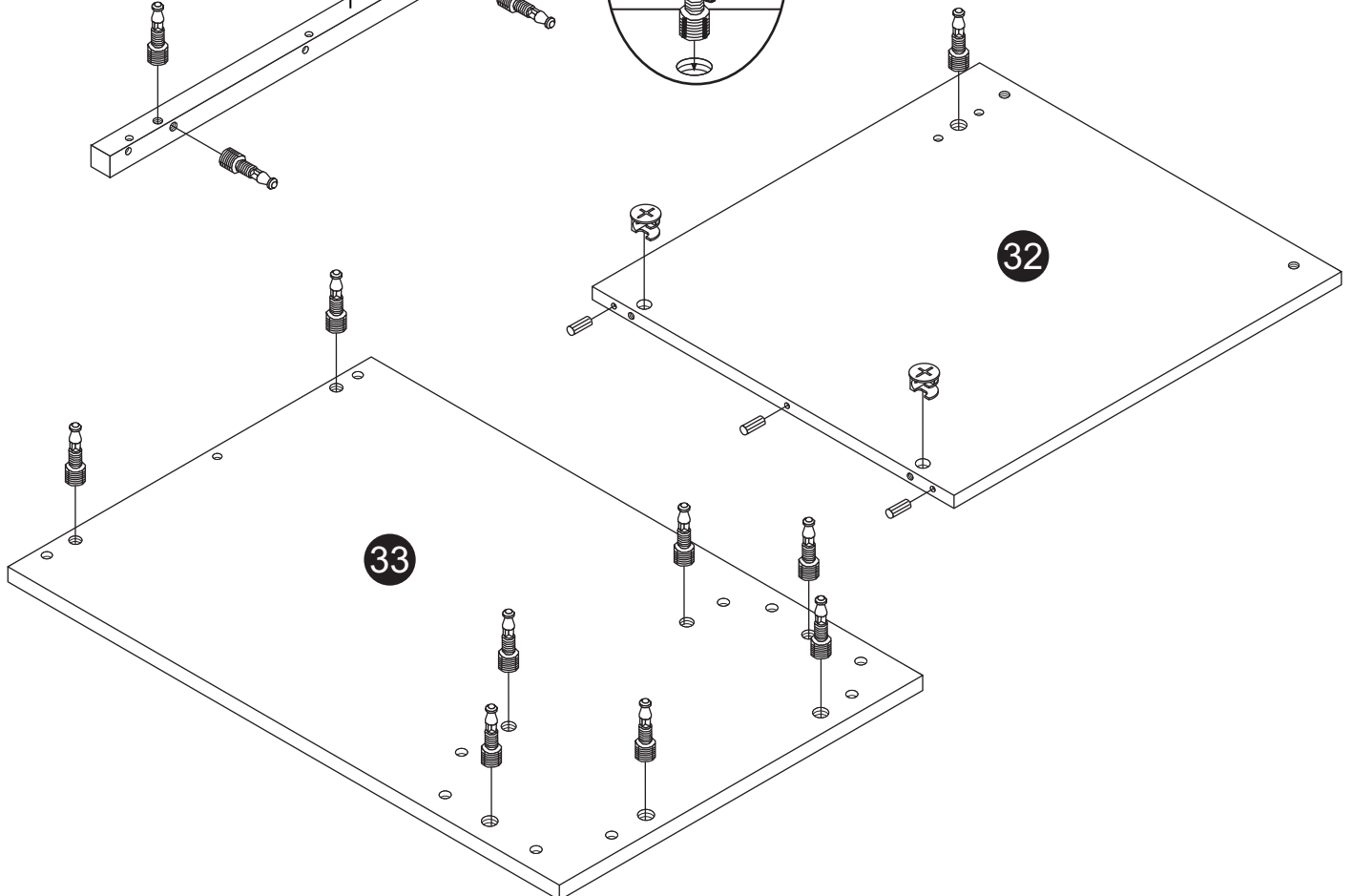
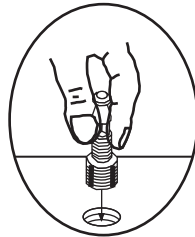
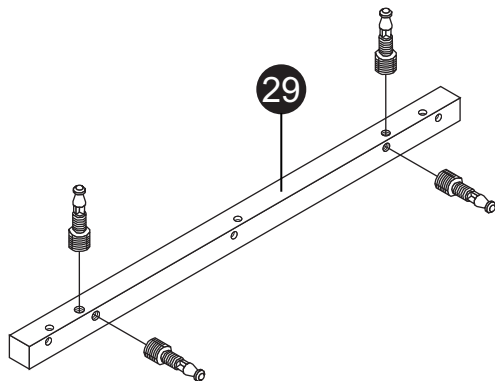
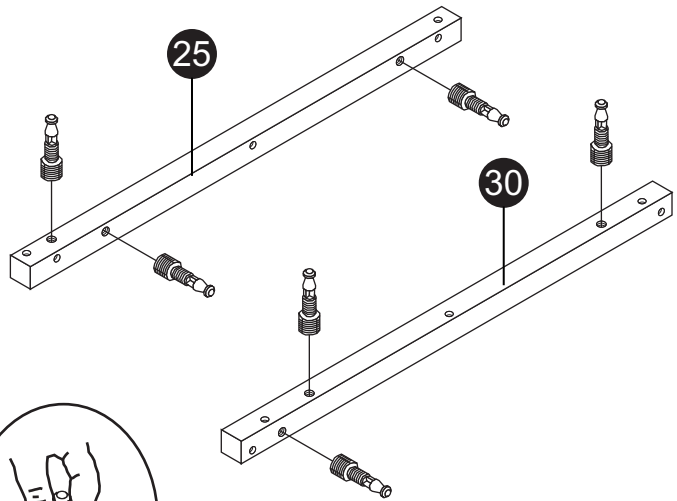
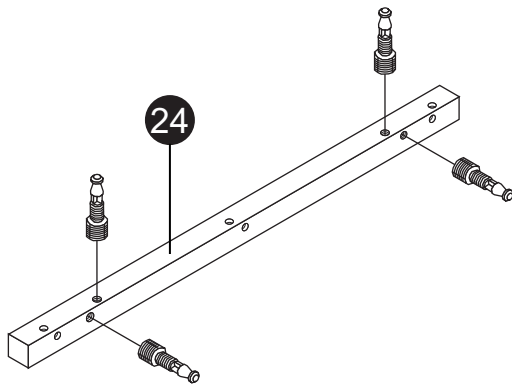

GUIDE TO ASSEMBLY

5
6

Model:

CK 6233

STEP 3



D x 4



F x 2

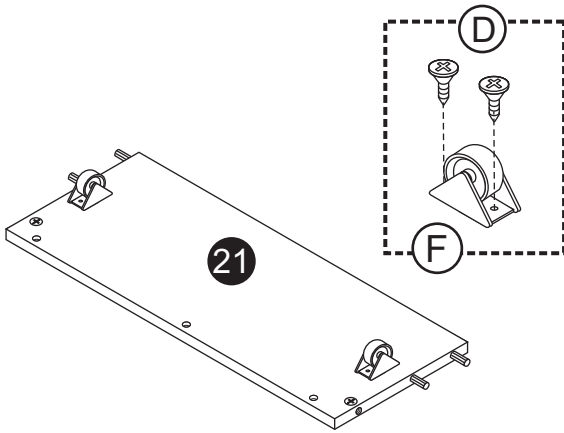

STEP 4

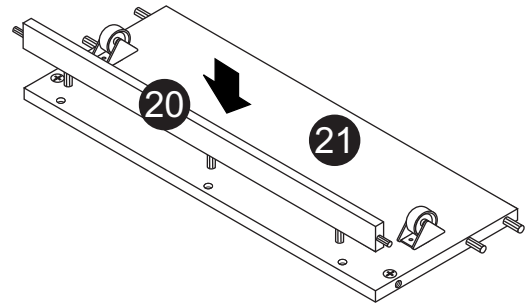

STEP 5

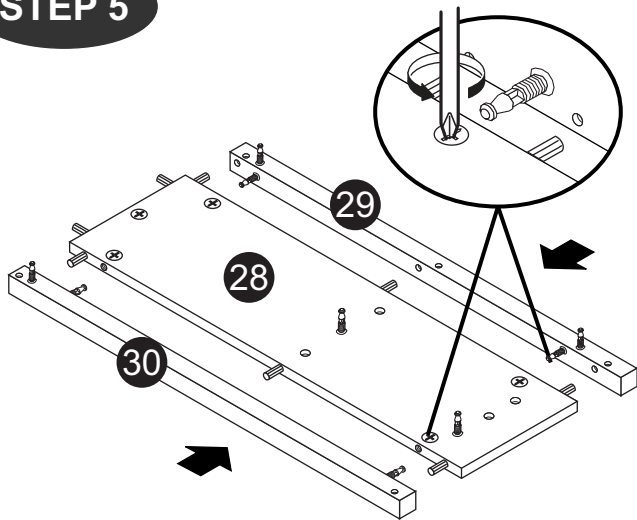

STEP 6

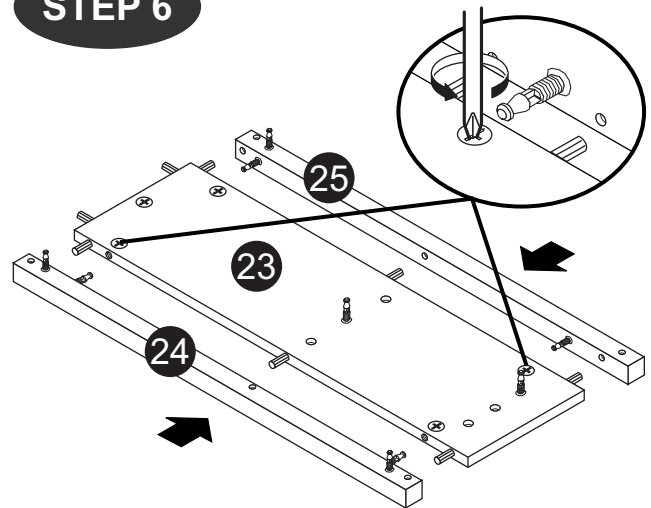

STEP 7

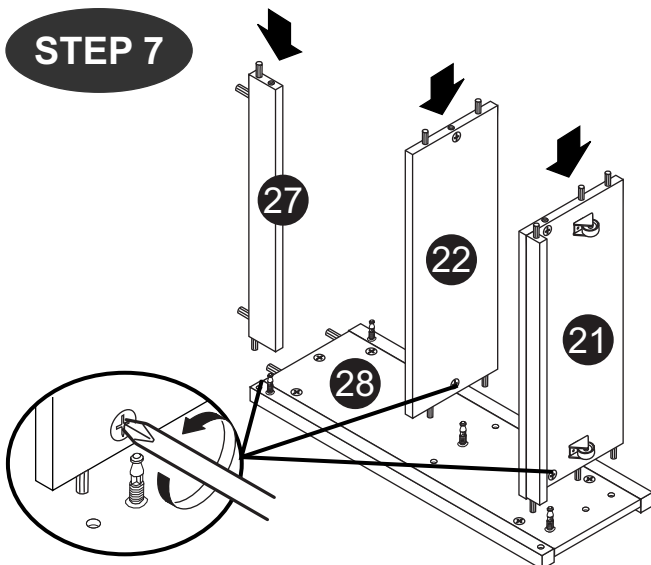

STEP 8

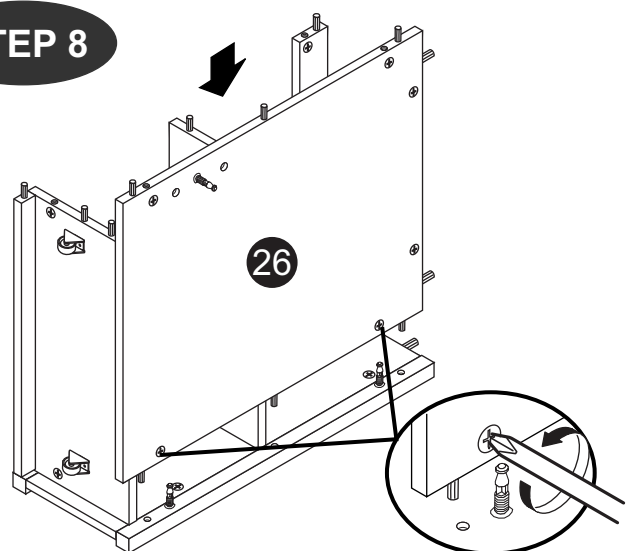

GUIDE TO ASSEMBLY

Model:

CK 6233

STEP 9

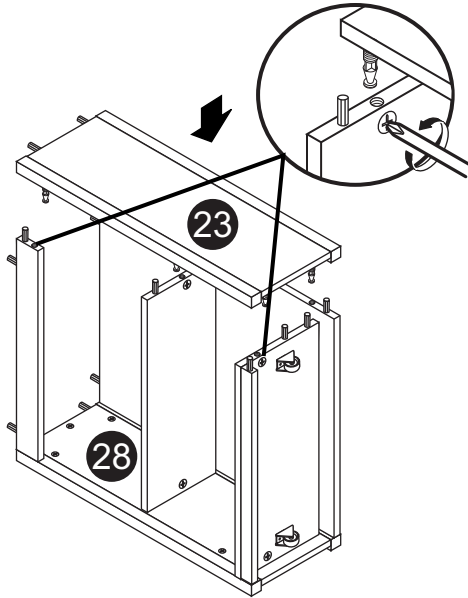

STEP 10

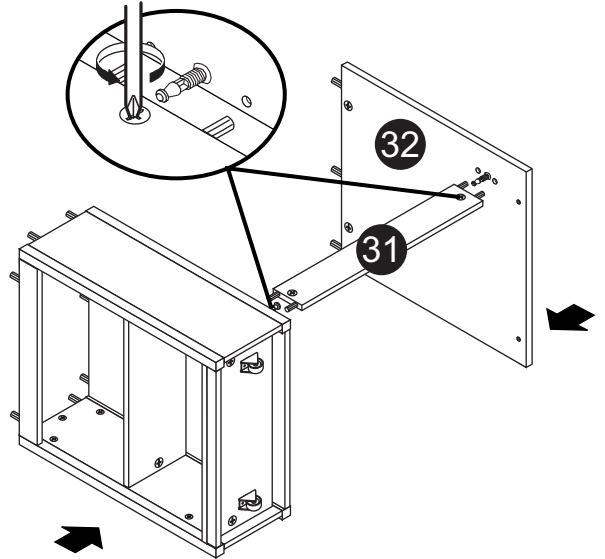

STEP 11



E x 2



G x 2



H x 2

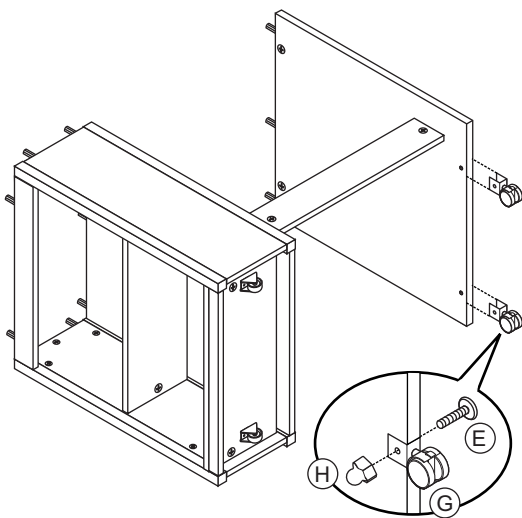

STEP 12

